

# M-410iB™ Series

## Basic Description

The M-410iB series is FANUC Robotics' latest-generation palletizing industrial robot. The unit is engineered for precision high-speed/high-payload operation, user-friendly setup, and maximum reliability supported by our extensive service and parts network. The M-410iB is a four-axis, electric servo-driven robot with an integrated mechanical and control unit designed for a wide variety of manufacturing and palletizing system processes.

## M-410iB, the Solution for:

- Case palletizing
- Bag palletizing
- Depalletizing
- Layer handling
- Press tending
- Machine load/unload
- Part transfer

## Benefits

- Fastest cycle times and highest payload in robot class.
- 20 cycles/min. case palletizing at 100 kg.
- 27 cycles/min. bag palletizing at 100 kg.
- Large allowable wrist inertias meet a variety of heavy handling challenges.
- High performance motion yields fast cycle times and high throughput.
- Small footprint and integrated controller reduces required floor space.
- Ability to service multiple production lines with large working envelope.
- Unique hollow RV speed reducers simplify cable routing.
- Proven, reliable FANUC servo drives provide highest uptime and productivity.
- Able to operate in environments ranging from harsh to traditional factory floor.



## Features

### Mechanical

- 4 axes of motion
- M-410iB/160: 160 kg payload capacity
- M-410iB/300: 300 kg payload capacity
- M-410iB/450: 450 kg payload capacity
- Dedicated pneumatic and electrical connections on J4 wrist to simplify user's end-of-arm tooling design, integration and communications (eight digital inputs/outputs, two 10 mm internal air lines).
- Adjustable J1 hard stops.
- Repeatability of +/- 0.5mm at full speed and full payload within entire work envelope.
- Direct-coupled drives on all axes results in higher reliability and reduced maintenance costs.
- Vertical articulation eliminates "elbow" interference issues related to SCARA robots.

### Controller

- Quick change amplifier <5 min.
- Fast boot time <30 sec.
- Standard Ethernet port
- PCMCIA software distribution.

- Easy connections to a variety of I/O, including a number of distributed I/O networks.

### Software

- Supports industry leading PalletTool® /PalletPRO™ software packages (palletizing setup, simulation and operation software).
- Supports CollisionGuard™ by servo control to minimize damage to the robot, gripper, cases/bags and peripherals.
- Web-based software tools for remote connectivity, diagnostics and production monitoring.
- Machine vision for robot guidance and inspection.

### Options

- Remote mount controller option with various robot connection cable lengths for flexible cabinet placement and optional track related cables.
- *i* Pendant, a color, Internet-ready teach pendant for even easier programming and custom cell user interface (Easy Panel).
- Integrated auxiliary axes packages.
- Servo hand package utilizing standard six-channel robot servo amp.

**FANUC**  
Robotics

# M-410iB/160/300 Dimensions

## Isometric

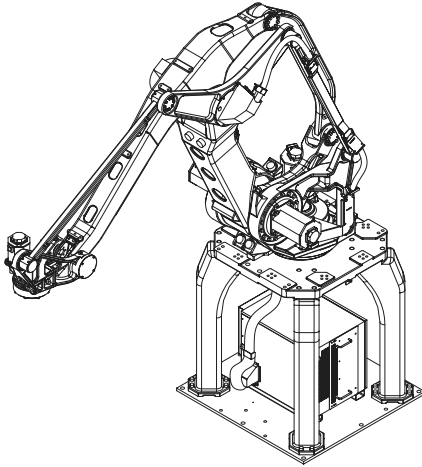

## Wrist

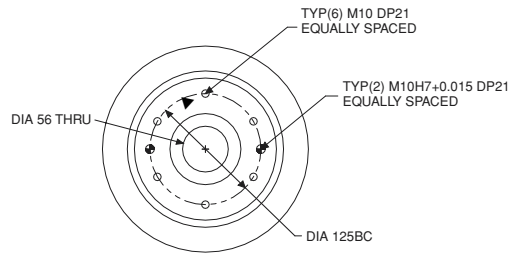

## Footprint

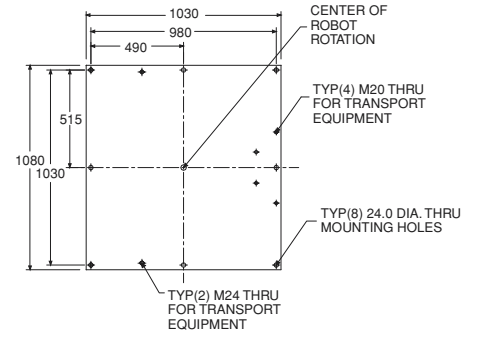

## Top

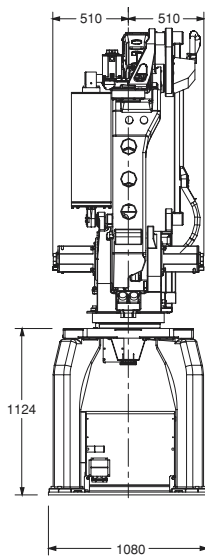
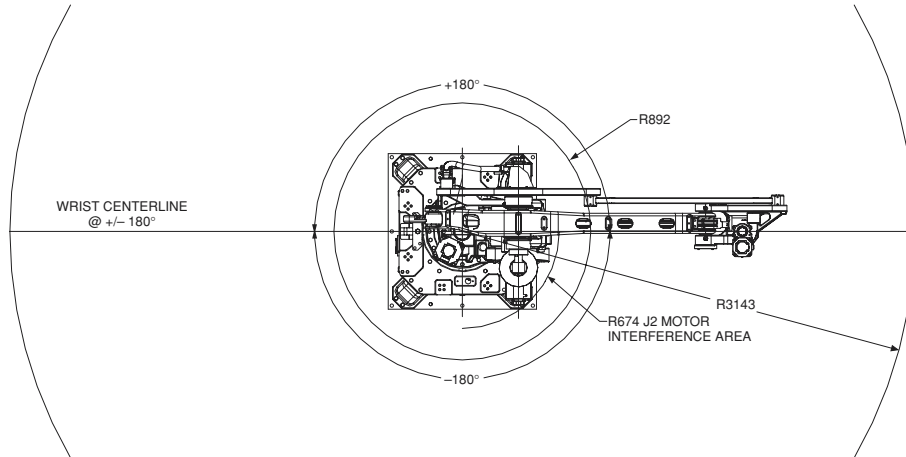

## Front

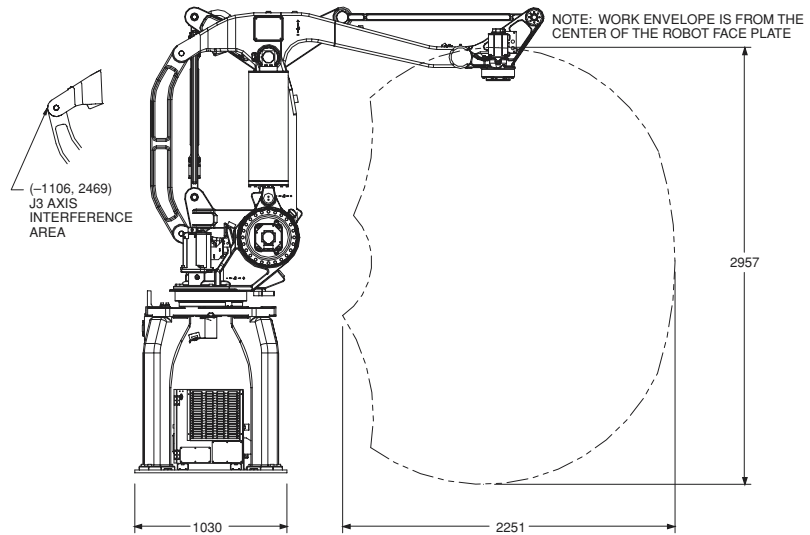

## Side

**Note:** Dimensions shown in millimeters.

# M-410iB/450 Dimensions

## Isometric

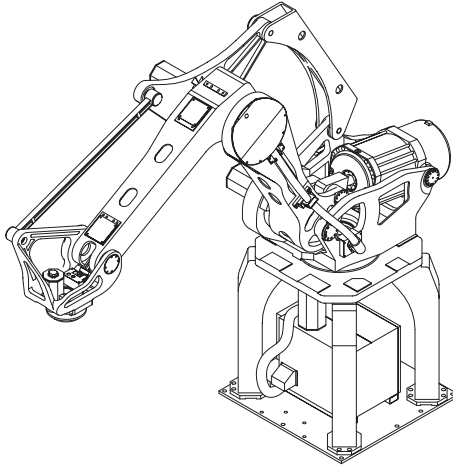

## Wrist

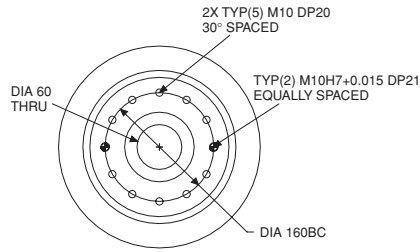

## Footprint

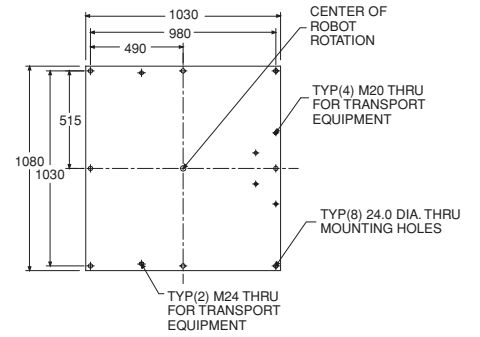

## Top

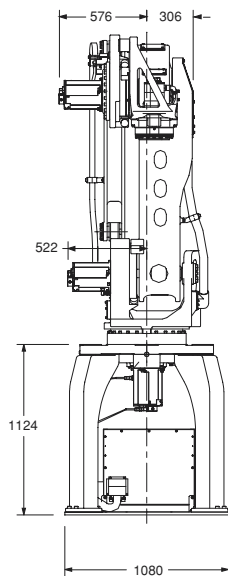
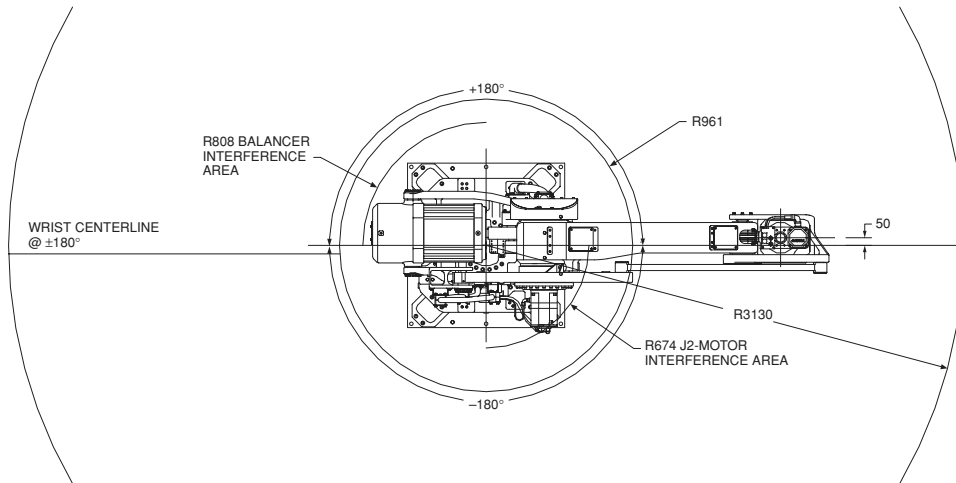

## Front

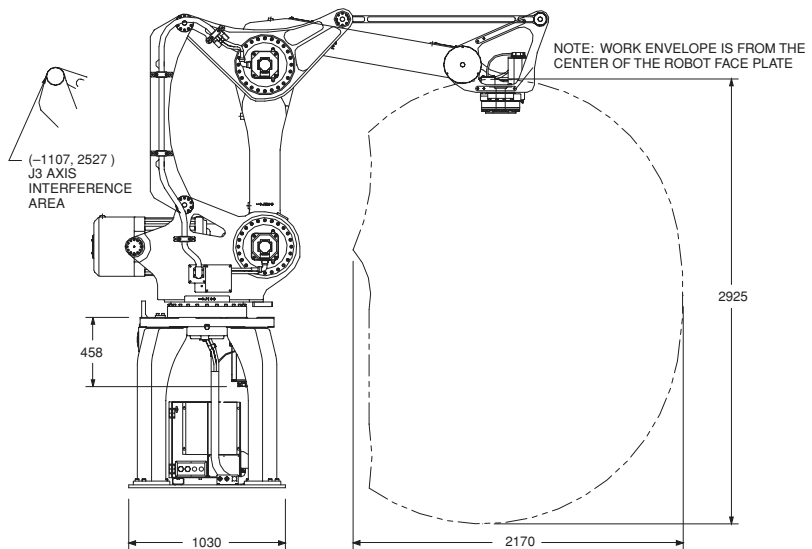

## Side

Note: Dimensions shown in millimeters.



**Corrugated Case Palletizing**

**Over 2,000 M-410i units installed in a variety of palletizing and part handling applications.**



**Layer Palletizing**



**Mixed Load Palletizing**

**M-410i/B Series Specifications**

Items	M-410iB/160	M-410iB/300	M-410iB/450	
Axes	4	4	4	
Payload (kg)	160	300	450	
Reach (mm)	3143	3143	3130	
Repeatability (mm)	± 0.5	± 0.5	± 0.5	
Interference radius (mm)	674	674	808	
Motion range (degrees)	J1	360	360	
	J2	144	144	
	J3	136	136	
	J4	540	540	
Motion speed <sup>1</sup> (degrees/sec.)	J1	130	85	
	J2	130	90	
	J3	135	100	
	J4	300	190	
Wrist inertia (kgf-cm-s <sup>2</sup> )	J4	800	1400	2000
Mechanical brakes	All axes	All axes	All axes	
Mechanical weight (kg) <sup>2</sup>	1940	1940	2430	
Mounting method	Floor (upright)	Floor (upright)	Floor (upright)	
Installation environment	Temperature °C	0 to 45	0 to 45	0 to 45
	Humidity	Normally: 75% or less Short term (within a month): 95% or less No condensation		
Vibration (m/s <sup>2</sup> )	4.9 or less			

**Notes:**

- (1) Maximum linear velocity for M-410iB Series is 2.5 m/sec.
- (2) Controller weight of 120 kg is included.



**FANUC Robotics America, Inc.**  
**3900 W. Hamlin Road**  
**Rochester Hills, MI 48309-3253**  
**(248) 377-7000**  
**Fax (248) 276-4133**

**For sales or technical information, call:**  
**1-800-47-ROBOT**

**marketing@fanucrobotics.com**  
**www.fanucrobotics.com**

**Charlotte, NC**  
**(704) 596-5121**

**Chicago, IL**  
**(847) 898-6000**

**Cincinnati, OH**  
**(513) 754-2400**

**Los Angeles, CA**  
**(949) 595-2700**

**Toledo, OH**  
**(419) 866-0788**

**Toronto, Canada**  
**(905) 812-2300**

**Montréal, Québec**  
**(450) 492-9001**

**Aguascalientes, Mexico**  
**52 (449) 910-8000**

**Sao Paulo, Brazil**  
**(55) (11) 3955-0599**